



Reliable PMW
Service & Maintenance Manual
Running Gear

“Quality & Service”

Table of Contents

<u>Introduction</u>	1
Overview	1
Safety Precautions	1
Initial Adjustments	1
<u>Hubs, Brake Drums, Rotors, and Bearings</u>	2
Hub, Brake Drum, and Rotor Removal	2
Brake Drum Inspection	2
Rotor Inspection	3
Seal Inspection / Replacement	3
Bearing Inspection / Replacement	4
Bearing Lubrication – Grease	4
Bearing Lubrication – Oil	6
Bearing Adjustment and Hub Installation	7
<u>Hydraulic Brake System</u>	8
Hydraulic Disc Brakes	8
Hydraulic Disc Brakes – Caliper Mounting	8
Hydraulic Disc Brakes – Troubleshooting Guide	9
Hydraulic Drum Brakes	10
Hydraulic Drum Brakes – Mounting	10
Hydraulic Drum Brakes – Troubleshooting Guide	11
Hydraulic Drum Brakes – Maintenance	13
<u>Electric Brake Systems</u>	14
Electric Drum Brakes	14
Electric Drum Brakes – Mounting	15
Electric Drum Brakes – Troubleshooting Guide	16
Electric Drum Brakes – Maintenance	18
<u>Leaf Spring Suspension Systems</u>	20
Suspension Types	20
Leaf Spring Suspension – Inspection and Maintenance	22
<u>Rubber Torsion Suspension Systems</u>	23
How the Rubber Torsion Suspension System Works	23
Direction of Travel	23
Rubber Torsion Suspension – Inspection and Maintenance	24
<u>Wheels and Tires</u>	24
Wheel Selection	24
Torque Requirements	24
Tires	25
Wheels and Tires – Inspection and Maintenance	26
<u>Operation</u>	26
Storage Preparation	26
Service after Prolonged Storage	26
Trip Preparation Checklist	27
Maintenance Schedule	28
<u>Warranty Policy</u>	29

Introduction

Overview

This manual is provided to assist you in understanding how to operate, service, and maintain your trailer running gear that has been manufactured by Reliable. Reliable is known for providing “*Quality and Service*” on all of the products we offer. All of the running gear products included in this manual have been designed and manufactured to meet our customers’ strict requirements of design, dimension, and strength.

The information included in this manual provides guidelines to provide safe, reliable methods of performing the outlined service and maintenance procedures. Before any service or maintenance is performed, please consult this manual for further information.

Safety Precaution

Appropriate service methods and proper repair procedures are essential for the safe, reliable operation of all running gear as well as the personal safety of the individual doing the work. This manual provides general directions for performing service and repair work with tested, effective techniques. Following these procedures and guidelines will help assure reliability.

There are numerous variations in procedures, techniques, tools, and parts for servicing axles, as well as in the skill of the individual performing the work. This manual cannot possibly anticipate all such variations and provide advice or cautions as to each. Accordingly, anyone who departs from the instructions provided in this manual must first establish that they neither compromise their personal safety or the vehicle integrity by their choice of methods, tools, or parts.

Initial Adjustments

Prior to operating your trailer and at the listed intervals, it is important to perform the following adjustments:

- Check the “*Wheel Nut Torque*” at 10, 25, 50 and 250 miles as outlined on page 24 of this manual.
- Check the “*Tire Pressure*” to the manufacturers’ requirements as outlined on page 25 of this manual.
- Check the “*Brake Adjustment*” at 250 miles as outlined on pages 14 & 20 of this manual.
- Check the “*Brake Synchronization*” before operating the trailer as outlined on page 18 of this manual.

Additional intervals of service and maintenance on the above items should be performed as outlined in the maintenance schedule on page 28 of this manual, or as use requires.

Hubs, Brake Drums, Rotors, and Bearings

Hub, Brake Drum, and Rotor Removal

When the hub, brake drum or rotor must be removed from the axle for inspection or maintenance, the following removal procedure should be used:

1. Lift and support the trailer frame per the trailer manufacturer's instructions.
2. Remove the wheel from the hub or brake drum.
3. Remove the grease cap carefully by prying around the flange of the cap as you turn the hub or brake drum.
4. Remove the cotter pin, which is keeping the spindle nut from turning, from the spindle.
5. Unscrew the spindle nut and remove the spindle washer.
6. Pull the hub, brake drum, or rotor toward you until the unit comes off of the spindle. Be careful not to let the outer bearing cone fall out of the hub or brake drum. The seal will retain the inner bearing cone.
7. The hub, brake drum or rotor should be set on a clean surface to keep any contamination from entering the bearing cavity of the hub.

Brake Drum Inspection

There are one or two areas on a brake drum that must be periodically inspected for wear. For both electric and hydraulic brakes, the inside diameter where the brake shoes contact the drum needs to be inspected.

When this diameter shows signs of excessive wear or heavy scoring, or if this diameter is worn out-of-round by more than .020", the drum needs to be turned. When re-turning the inside diameter of the brake drum, the following sizes should be used for the maximum bore diameter:

- 7" Brake Drums = 7.090" Diameter
- 10" Brake Drums = 10.060" Diameter
- 12" Brake Drums = 12.090" Diameter

If this diameter is worn to the point that it will not clean up at the above diameters, the brake drum should be replaced.

For electric brakes, a second surface also must be inspected. This surface is located where the brake magnet contacts the inner face on the brake drum. This surface is called the armature face.

When this face shows signs of excessive wear or heavy scoring, or if this face is worn out-of-flat by more than .020", this face needs to be turned. Any time the armature face is turned to clean-up excessive wear, the brake magnets should also be replaced.

IMPORTANT: *If the drum must be turned, it is important that the grease that is in the bearing cavity and the bearings are protected from contamination. If contamination does enter the bearing area of the brake drum, the brake drum must be disassembled and cleaned prior to reassembly.*

Rotor Inspection

There is one area on a rotor that must be periodically inspected for wear. Both outside faces where the brake pads contact the rotor face need to be inspected. When this face shows signs of excessive wear or heavy scoring, or if this face is worn out-of-flat by more than .020”, the rotor face needs to be turned.

BT Rotor (8 ¼” outside diameter) = .38” Minimum Thickness

UHI Rotor (10 ¼” outside diameter) = .85” Minimum Thickness

HRM Rotor (12 ½” outside diameter) = .85” Minimum Thickness

If this face is worn to the point that it will not clean up to the above dimensions, the rotor should be replaced.

IMPORTANT: *If the rotor must be turned, it is important that the grease that is in the bearing cavity and the bearings are protected from contamination. If contamination does enter the bearing area of the rotor, the rotor must be disassembled and cleaned prior to reassembly.*

Seal Inspection / Replacement

The seal should be inspected any time the hub or brake drum is removed from the axle or at intervals as outlined in the maintenance schedule shown on page 28 of this manual. The seal lip should show no signs of being torn or nicked and be capable of properly keeping contamination out of the bearing housing. If a seal does need to be replaced, follow the procedure as outlined and only use seals that are approved for use in the following chart. When changing seals in a hub equipped with the Sure Lube greasing system, it is especially important to use only the brand name and exact number as shown in the chart.

The following procedure should be used for seal replacement:

1. Pry the seal out of the hub. Do not try to push the seal through using the inner bearing, as this can cause the inner bearing to be damaged.
2. Apply a Permatex (or equivalent) sealant around the outside diameter of the seal. (Rubber case seals do not require any sealant.)
3. Tap the new seal back into the hub using a clean wood block.

IMPORTANT: *The seal must be flush or slightly above the top of the hub especially if the hub is equipped with the Sure Lube greasing system.*

Seal Interchange					
Inner Bearing Cone Number	Seal Diameter on Spindle	Reliable Part #	Transcom Part #		National Seal Part #
			Metal Case	Rubber Case	
L44643	1.23/1.25”	SL-122-1	12192TB	12194TC	471750
L44649	1.23/1.25”	SL-122-1	12192TB	12194TC	471750
L44649	1.50”	SL-150-1	15192TB	15192TC	N/A
L68149	1.68”	SL-168	168255TB	168255TC	470460
L68149	1.72”	SL-173	171255TB	171255TC	473336
25580	2.13”	SL-213-1	21334TB	21334TC	413470

Bearing Inspection / Replacement

The bearings should be inspected any time the hub or brake drum is removed from the axle or at intervals as outlined in the maintenance schedule shown on page 28 of this manual. The bearing cones should show no signs of excessive wear or damage such as flat spots on the rollers, broken cages, pitting, or corrosion. The bearing cups that are pressed into the hub should also be checked for wear or damage. If the bearings do need to be replaced, follow the procedure as outlined and only use bearings that are approved for use in the following chart.

IMPORTANT: *Both the bearing cup and bearing cone should be replaced any time a bearing is replaced.*

The following procedure should be used for bearing cup replacement:

1. Carefully tap the existing bearing cup out of the hub using a brass punch.
2. Clean the bore area after removing the cup to ensure there are no nicks or burrs.
3. Carefully tap the new bearing cup into the hub making sure the cup is seated against the bottom of the bore.

Bearing Replacement & Interchange						
Axle Capacity	# of Bolts	Spindle Type	Inner Bearings		Outer Bearings	
			Cup	Cone	Cup	Cone
1000# - 2500#	4 or 5	Straight	L44610	L44643	L44610	L44643
1000# - 2700#	4 or 5	Straight	L44610	L44649	L44610	L44649
2500# - 3700#	5	Tapered	L68111	L68149	L44610	L44649
4000# - 5500#	6	Tapered	25520	25580	LM67010	LM67048
5000# - 6000#	6	Tapered	25520	25580	15245	15123
6000# - 7000#	8	Tapered	25520	25580	14276	14125A

Bearing Lubrication - Grease

Below is a listing of approved lubrication for all Reliable hubs and drums using grease for lubrication:

Lubrication Specifications		Approved Sources
Grease		Exxon Ronex MP or equivalent
Soap Type	Lithium Complex or Equivalent	
Consistency	NLGI Grade 2	
Dropping Point	230°C (446°F) Minimum	
Additives	Corrosion and Oxidation Inhibitors, EP optional	
Base Oil	Solvent refined petroleum oil	
Viscosity Index	80 Minimum	

For units equipped with the Sure Lube or Bearing Lube greasing systems, the bearings can be lubricated without the hassle of packing the bearings by hand. After assembling the unit, simply apply grease through the grease fitting that is in the end of the grease cap or spindle. The grease used should meet the requirements as shown in the chart above. The following amounts of grease should be used:

- 5-7 ounces to completely exchange the grease throughout the hub
- 1 ½ - 3 ounces every (6) months or 3000 miles thereafter or as use requires

1. Sure Lube Lubrication System

With the Sure Lube System the grease is pumped through the hub via the grease zert located in the end of the grease cap. The grease is forced through the bearings and out the exit hole ahead of the seal. The old grease that is inside of the hub is forced out of the hub cavity and exits through the rear hole on the spindle. You can visibly tell when the old grease is flushed out when you see a steady flow of the new grease coming from the rear of the spindle (with exception to the straight style of axles). The grease can then be wiped from the rear of the spindle or, in the case of a straight axle, the grease will flow inside of the axle tube.

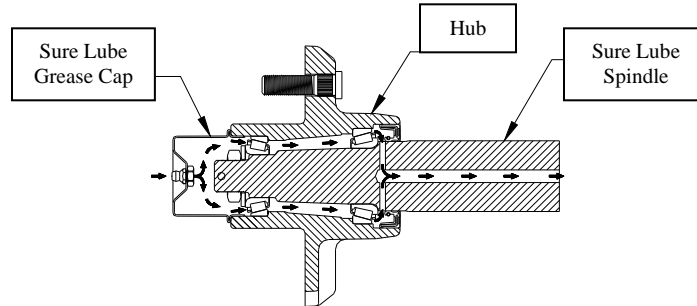

2. Bearing Lube Lubrication System

With the Bearing Lube System the grease is applied through a grease zert located in the end of the wheel spindle. This grease zert is found by removing the rubber plug in the end of the grease cap. The grease is pumped through the spindle, out of the entry hole located just ahead of the seal lip, through the bearing cones and then out the end of the hub. You will notice a steady flow of new grease appear at the end of the hub where you are greasing when the old grease is flushed from the hub. Replace the rubber plug when lubrication is completed.

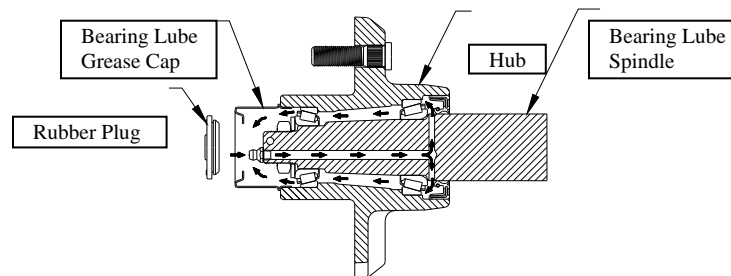

For units that are not equipped with the Sure Lube or Bearing Lube greasing system, the bearings must be packed with grease (by hand) prior to assembly, or at intervals as outlined in the maintenance schedule on page 28 of this manual.

Bearing Lubrication – Oil

Below is a listing of approved lubrication for all Reliable hubs and drums using oil for lubrication:

(Only to be used when unit is equipped with the Oil Bath Lubrication System)

Lubrication Specifications	
Oil	Approved Sources
SAE 90 Hypoid Gear Oil	Valvoline Gear Oil 80W-90
	Exxon Gear Oil 80W-90

1. Oil Bath Lubrication System – Aluminum Cap

With the Oil Bath Lubrication System using the aluminum cap, the oil is applied through a hole located in the side of the oil bath cap. This hole is found by removing the fitting from the side of the oil bath cap. The oil is filled through the hole until it reaches the half-way point on the sight glass in the oil bath cap. The oil level should be kept at the half-way point on the sight glass or slightly higher at all times. If this cap has to be removed it will have to be replaced with a new press-in style Reliable aluminum Oil Bath Cap.

2. Oil Bath Lubrication System – Plastic Cap

With the Oil Bath Lubrication System using the plastic cap, the oil is applied through a hole located in the side of the hub.

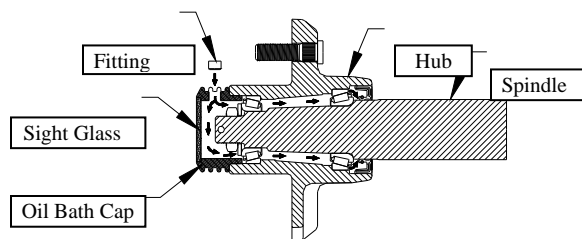

This hole is found by removing the fitting from the side of the hub located in the pilot that protrudes through the wheel. The oil is filled through the hole until it reaches the top of the Reliable logo found on the sight glass in the oil bath cap. The oil level should be kept at this point or slightly higher at all times. If this cap has to be removed it can be unscrewed using the appropriate socket size shown in the chart below. When reinstalling check the condition of the o-ring, replace if necessary, and use the torque specification provided in the chart below.

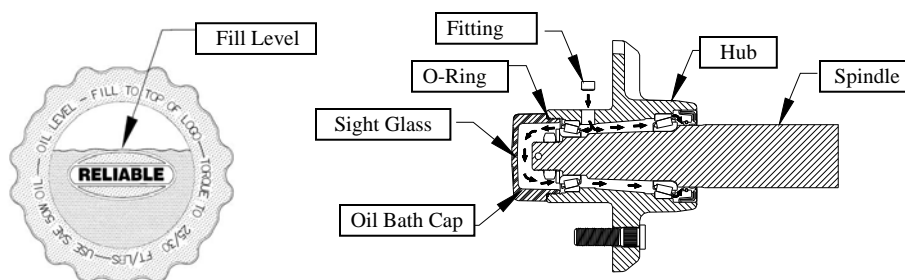

Oil Bath Lubrication System – Screw-In Cap Information			
Size	O-Ring Number	Socket Size	Torque Specification
5 Bolt	01-137	2 3/8" 6 Point	25-30 ft./lbs.
6 Bolt	01-143	2 7/8" 6 Point	

Bearing Adjustment and Hub Installation

Bearing adjustment is a very important part of achieving maximum bearing life and trouble-free service. Most bearing failures can be attributed to improper bearing adjustment, normally due to the bearings being adjusted too tight.

Once all of the necessary inspections have been performed and the units have been properly lubricated, the following procedure should be used for reinstallation of the hubs:

1. Place the lubricated unit onto the same spindle from which it was removed. Make sure all of the components are reinstalled as they were removed.
2. Tighten the spindle nut to 30-40 ft.-lbs. while turning the hub to ensure the bearings are properly seated. Do not move the hub after this step is completed.
3. Loosen the spindle nut completely until the nut can be turned with your fingers.
4. Finger-tighten the spindle nut by hand without moving the hub.
5. If the cotter pin **can** be assembled with the nut finger-tight, insert the cotter pin without backing the nut off. If the cotter pin **cannot** be assembled with the nut finger-tight, back the spindle nut up to the next available slot and insert the cotter pin.
6. Bend the legs of the cotter pin over the top of the spindle to ensure the spindle nut will not back off.
7. The spindle nut should be free to move with your fingers with only the cotter pin holding it in place and the hub should not have noticeable movement when pulled back and forth.

Hydraulic Brake Systems

The hydraulic disc or drum brakes on your trailer are similar to the brakes on an automobile. The hydraulic fluid from a master cylinder is used to actuate the brake cylinder. This causes the brake pads to apply force against the disc brake rotor or brake drum. The main difference between automotive brakes and trailer brakes is the actuation system.

A surge type actuator actuates trailer brakes, which is a type of coupler with a master cylinder built in. When the tow vehicle brakes are applied, the tow vehicle decelerates the weight of the trailer to apply force to the actuator. This force actuates the master cylinder, which in turn applies hydraulic pressure to the brakes.

Hydraulic Disc Brakes

The Reliable Disc Brake System is compatible with many of today's actuators. Please contact our sales department for a listing of actuators approved for use with the Reliable Disc Brake System.

Hydraulic Disc Brakes – Caliper Mounting

When installing the Reliable Disc Brake System, the caliper must be mounted in the correct position to allow the brake system to be bled properly. The Bleeder Valve must always be in the "UP" position, regardless of the hand (left or right) the caliper has stamped on it.

When installing the Reliable Disc Brake system, there are two M11 x 1.5 bolts that attach the caliper to the mounting flange along with an M10 x 1.5 oil inlet bolt that holds the banjo block into position. The following torque requirements should be used during assembly:

(2) M11 x 1.5 Caliper Attaching Bolts: **38-40 ft./lbs.**

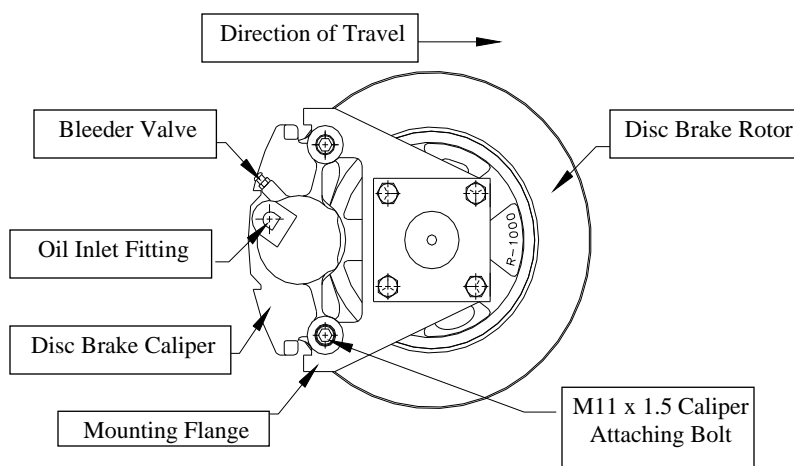

Hydraulic Disc Brakes – Troubleshooting Guide

SYMPTOM	CAUSES	REMEDIES
No Brakes	Broken or kinked brake line	Repair or Replace
	Malfunctioning Actuation System	Troubleshoot System
Weak Brakes	Worn or Contaminated Pads	Replace Brake Pads
	Incorrect Brake Pad	Install Correct Brake Pads
	Frozen Master Cylinder /Caliper Cylinder	Recondition or Replace Cylinders
	Glazed Brake Pads	Reburnish or Replace
	Excessive Rotor Face Wear	Replace or Recondition
	Trapped Air In Lines	Bleed System
	Overloaded Trailer	Correct
	Faulty Actuator	Troubleshoot System
Pulls to One Side	Incorrect Tire Pressure	Inflate Evenly On Both Sides
	Unmatched Tires On Same Axle	Match Tires On Axle
	Restricted Brake Lines or Hoses	Repair or Replace
	Malfunctioning Caliper	Check Caliper Pistons
	Defective Brake Pads	Install New Brake Pads
Dragging Brakes	Unpunctured Check Valve	Replace Actuator
	Blocked Master Cylinder	Replace or Recondition
	Improper Brake Fluid	Fill with DOT3 Fluid

Hydraulic Drum Brakes

Reliable offers two styles of hydraulic drum brakes. Uni-servo style hydraulic drum brakes utilize a single acting cylinder. When actuated, the primary shoe is pressed against the brake drum, which causes the shoe to move in the direction of the rotation. Through the adjuster link assembly, the motion of the primary shoe causes the secondary shoe to engage.

Another variation of the hydraulic drum brake offered by Reliable is the “free backing” hydraulic drum brake. This is commonly used in combination with the surge type hitch. When backing up with a surge brake hitch, the brakes are applied through the surge mechanism, and if there is more brake force on the trailer than the tow vehicle can override, no backing is possible. The free backing brake was developed to allow backing in this application. This brake has a primary shoe on a pivot, which allows normal application in the forward direction, but allows the primary shoe to rotate away from the drum surface when backing.

Hydraulic Drum Brakes – Mounting

When installing hydraulic drum brakes, the primary or “short” shoe must face the front of the trailer. This is the braking surface that initiates the force to actuate the secondary or “long” shoe. Depending on the capacity of the brake (4) or (5) bolts and locking nuts must be used to secure the brake backing plate to the spindle flange.

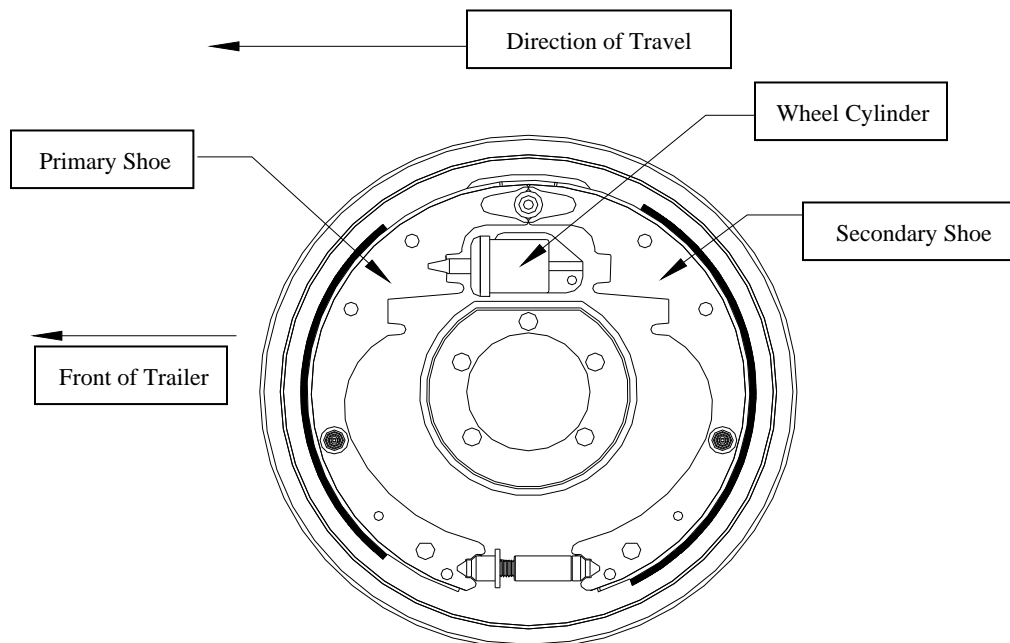

Hydraulic Drum Brakes – Troubleshooting Guide

SYMPTOM	CAUSES	REMEDIES
No Brakes	Broken or kinked Brake Line	Repair or Replace
	Severe Underadjustment	Adjust Brakes
	Malfunctioning Actuation System	Troubleshoot System
Weak Brakes	Brake Adjustment Not Correct	Adjust Brakes
	Excessively Worn Brake Linings	Replace Shoe & Lining
	Incorrect Linings	Install Correct Shoe & Lining
	Grease or Fluid Soaked Lining	Repair Seal & Replace Linings
	Frozen Master or Wheel Cylinders	Recondition or Replace Cylinders
	Glazed Lining	Reburnish Or Replace
	Excessive Drum Wear	Replace
	Trapped Air In Lines	Bleed System
	Overloaded Trailer	Correct
	Faulty Actuator	Troubleshoot System
	Harsh Brakes	Brake Adjustment Not Correct
Grease or Fluid Soaked Linings		Repair Seal & Replace Linings
Surging Brakes	Grease or Fluid Soaked Linings	Repair Seal & Replace Linings
	Faulty Actuator	Troubleshoot System

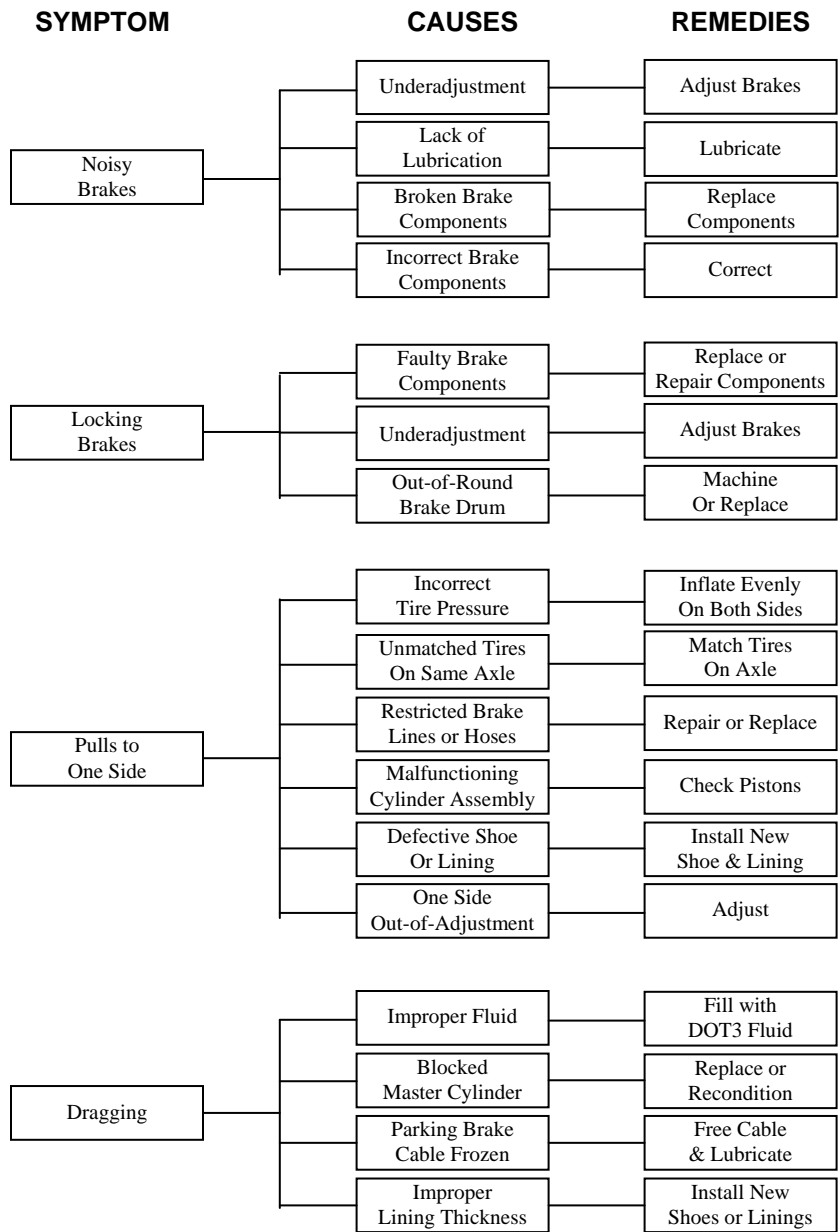

Hydraulic Drum Brakes – Maintenance

Typically there is no special maintenance required on a properly installed hydraulic brake system, with the exception of routine maintenance such as the replacement of brake shoes and linings. If problems do arise, they are typically related to leaks or air in the brake lines, impurities in the brake fluid, or corroded master or wheel cylinders. Specific maintenance activities are as follows:

- **Hydraulic Drum Brakes – Wheel Cylinders**
A visual inspection of the wheel cylinders should be carried out periodically to inspect for smooth operation and leaks. The wheel cylinders may be cleaned with brake cleaner and flushed with fresh brake fluid.
- **Hydraulic Drum Brakes – Brake Shoes & Linings**
Replace brake linings if they have become contaminated by grease, worn or abnormally scored or gouged.
- **Hydraulic Drum Brakes – Brake Fluid**
It is important that the level of brake fluid be checked on a regular basis and replaced every 2 years.
- **Hydraulic Drum Brakes – Brake Lines**
Visually check for cracks, kinks or leaks. The system may be bled to remove any air in the system.
- **Hydraulic Drum Brakes – Bleeding of Brake System**
In order for your hydraulic system to function properly you will need to bleed the air from the system.

To bleed air from the brake system, follow the procedure outlined below:

1. Fill the master cylinder with a DOT3 approved brake fluid.
2. On tandem axle applications, the rear axle on the trailer should be bled first.
3. Attach bleeder hose on the bleeder screw of the first wheel cylinder to be bled. Submerge the opposite end of the bleeder hose into a glass container filled with brake fluid. The purpose of the glass container is to observe any air bubbles in the system.
4. Loosen the bleeder screw one full turn. Pump the actuator with long steady strokes while watching the glass container for bubbles. When bubbles no longer rise to the surface of the fluid, the bleeding operation is complete.
5. Remove bleeder hose and tighten bleeder screw.
6. To avoid air being forced back into the system, do not let the master cylinder run dry during the bleeding process. The master cylinder may need to be replenished after bleeding each wheel cylinder.
7. Repeat the bleeding process until all of the air is removed.
8. Fill the master cylinder reservoir with fluid and replace the cap.

- *Hydraulic Drum Brakes – Adjustment*

Hydraulic drum brakes should be adjusted (1) after the first 250 miles of operation when the brake shoes and drums have “*seated*”, (2) at 1000 mile intervals, or (3) as use and performance requires. The brakes should be adjusted in the following manner:

1. Jack up the trailer and secure on adequate capacity jack stands. Follow the trailer manufacturer’s recommendations for lifting and supporting the unit. Check that the wheel and drum rotates freely.
2. Remove the adjusting hole cover from the adjusting slot on the bottom of the brake backing plate.
3. With a screwdriver or standard adjusting tool, rotate the starwheel of the adjuster assembly to expand the brake shoes. Adjust the brake shoes out until the pressure of the linings against the drum makes the wheel very difficult to turn.
4. Rotate the starwheel in the opposite direction until the wheel turns freely with a slight lining drag.
5. Replace the adjusting hole cover and lower the wheel to the ground.

Electric Brake Systems

Electric Drum Brakes

The electric brakes on your trailer are similar to the drum brakes on an automobile. The basic difference is that your trailer brakes are actuated by an electromagnet. With all of the brake components connected into the system, the brakes will operate as follows:

When electrical current is fed into the system by the controller, it flows through the electromagnets in the brakes. The high capacity electromagnets are energized and are attracted to the rotating armature surface of the drums, which moves the actuating levers in the direction that the drums are turning. The resulting force causes the actuating cam block at the shoe end of the lever to push the primary shoe out against the inside surface of the brake drum. The force generated by the primary shoe acting through the adjuster link then moves the secondary shoe out into contact with the brake drum.

Increasing the current flow to the electromagnet causes the magnet to grip the armature surface of the brake drum more firmly. This results in the pressure being increased against the shoes and brake drums until the desired stop is accomplished.

Electric Drum Brakes – Mounting

When installing electric drum brakes, the primary or “*short*” shoe must face the front of the trailer. This is the braking surface that initiates the force to actuate the secondary or “*long*” shoe. Depending on the capacity of the brake, (4) or (5) bolts and locking nuts must be used to secure the brake backing plate to the spindle flange.

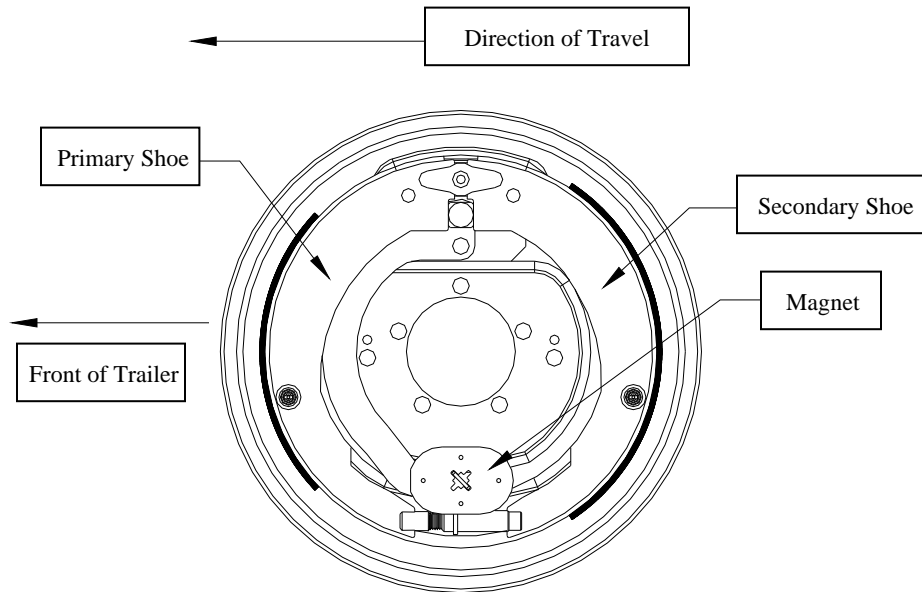

Electric Drum Brakes – Troubleshooting Guide

SYMPTOM	CAUSES	REMEDIES
No Brakes	Open Circuits	Find & Correct
	Severe Underadjustment	Adjust Brakes
	Faulty Controller	Test & Correct
	Short Circuits	Find & Correct
Weak Brakes	Grease on Magnet or Lining	Clean or Replace
	Corroded Connectors	Clean & Correct Cause of Corrosion
	Worn Lining Or Magnet	Replace
	Scored or Grooved Brake Drum	Machine Or Replace
	Improper Synchronization	Correct
	Underadjustment	Adjust Brakes
	Glazed Linings	Reburnish Or Replace
	Overloaded Trailer	Correct
Locking Brakes	Underadjustment	Adjust
	Improper Synchronization	Correct
	Faulty Controller	Test & Correct
	Faulty Brake Components	Replace Components
	Insufficient Wheel Load	Adjust System Resistor
	Out-of-Round Brake Drum	Machine or Replace

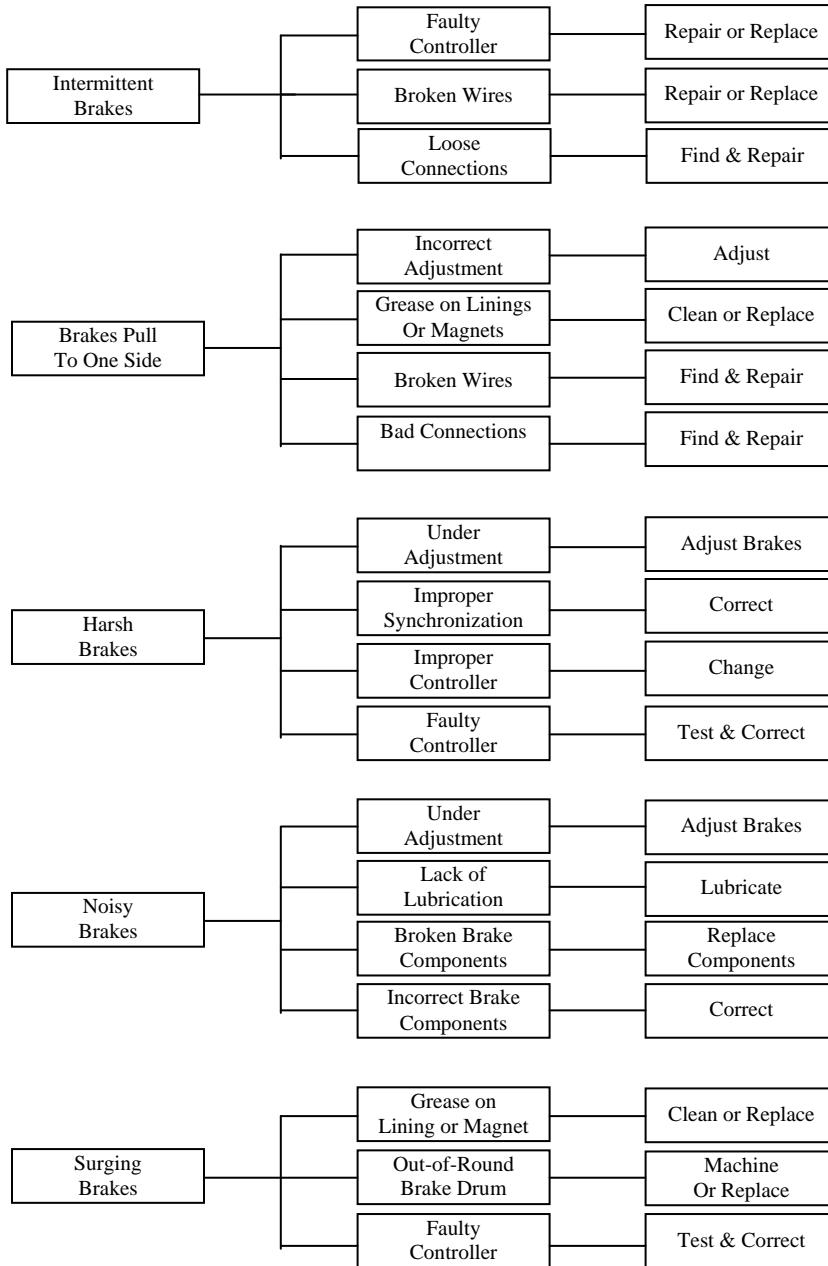
SYMPTOM**CAUSES****REMEDIES**

Electric Drum Brakes – Maintenance

Typically there is no special maintenance required on a properly installed electric brake system, with the exception of routine maintenance such as replacement of the brake shoes and linings. If problems do arise, they are typically related to the synchronization of the brake system or the brake controller.

Specific maintenance activities are as follows:

- *Electric Drum Brakes – Synchronization*

Your trailer brakes are designed to work in synchronization with your tow vehicle brakes. Never use your tow vehicle or trailer brakes alone to stop the combined load.

Your trailer and tow vehicle will seldom have the right amperage flow to the brake magnets to give you comfortable, safe braking unless you make proper brake system adjustments. Changing trailer load and driving conditions as well as uneven alternator and battery output can mean unstable current flow to your brake magnets. It is, therefore, imperative that you maintain and adjust your brakes as set forth in this manual, use a properly modulated brake controller, and perform the synchronization procedure noted below.

In addition to the synchronization adjustment detailed below, electric brake controllers provide a modulation function that varies the current to the electric brakes with the pressure on the brake pedal. It is important that your brake controller provide approximately 2 volts to the braking system when the brake pedal is first depressed and gradually increase the voltage to 12 volts as brake pedal pressure is increased. If the controller “*jumps*” immediately to a high voltage output, even during a gradual stop, then the electric brakes will always be fully energized and will result in harsh brakes and potential brake lockup.

Proper synchronization of tow vehicle to trailer braking can only be accomplished by road testing. Brake “*lockup, grabbiness, or harshness*” is quite often a lack of synchronization between the tow vehicle and the trailer being towed, too high of a threshold voltage (over 2 volts), or underadjusted brakes.

There are two synchronization adjustments available:

1. ***System Resistor*** – regulates the maximum braking power of the trailer brakes.
2. ***Brake Controller*** – controls the tow vehicle brake line pressure at which the controller will begin to pass current to the trailer brakes.

Before synchronization adjustments are made, your trailer brakes should be burnished-in by making 10-12 full stops from approximately 20 mph. This allows the brake shoes and magnets to slightly “*wear-in*” to the drum surfaces.

Start by making sure the trailer brakes are properly adjusted (See page 20). Set the System Resistor in the middle of the coil and the Controller adjustment near the center of its setting.

Make hard stops from 20 mph on a dry paved road free of sand and gravel. If the trailer brakes lock and slide, add more resistance to the circuit with the System Resistor. If they do not slide, take resistance out of the circuit. Adjust the resistor just to the point of brake lockup and wheel skid.

Make a number of 30 mph hard stops to check braking at this speed. If the trailer brakes lag behind the tow vehicle, turn the Controller adjustment in the direction for more braking. If the trailer brakes come in ahead of the tow vehicle brakes, turn the Controller adjustment in the opposite direction. For best braking performance, it is recommended that the Controller be adjusted to allow the trailer brakes to come in just slightly ahead of the tow vehicle brakes. When proper synchronization is achieved there will be no sensation of the trailer “*jerking*” or “*pushing*” the tow vehicle during braking.

When this adjustment is complete, make a hard stop or two from 20 mph to check for wheel lockup and whether further fine-tuning of the System Resistor is required.

- *Electric Drum Brakes – Cleaning and Lubricating*

Your trailer brakes must be inspected and serviced at yearly intervals or as use and performance requires. Magnets and shoes must be changed when they become worn or scored, thereby preventing adequate vehicle braking.

Clean the backing plate, magnet arm, magnet, and brake shoes. Make certain that all the parts removed are replaced in the same brake and drum assembly. Inspect the magnet arm for any loose or worn parts. Check shoe return springs, hold down springs, and adjuster springs for stretch or deformation and replace if required.

Before reassembling, apply a light film of Lubriplate or similar grease on the brake anchor pin, the actuating arm bushing and pin, and the areas on the backing plate that are in contact with the brake shoes and magnet lever arm. Apply a light film of oil on the actuating block mounted on the actuating arm.

CAUTION: Do not get grease or oil on the brake linings or drums.

- *Electric Drum Brakes – Magnets*

Your electric brakes are equipped with high quality electromagnets that are designed to provide the proper input force and friction characteristics. Your magnets should be inspected and replaced if worn unevenly or abnormally.

Even if wear is normal, the magnets should be replaced if any part of the magnet coil has become visible through the friction material facing of the magnet. It is also recommended that the drum armature surface be refaced when replacing magnets. (See Brake Drum Section on page 14). Magnets should also be replaced in pairs (both sides of an axle).

- Electric Drum Brakes – Adjustment

Brakes should be adjusted (1) after the first 250 miles of operation when the brake shoes and drums have “*seated*”, (2) at 1000-mile intervals, or (3) as use and performance requires. The brakes should be adjusted in the following manner:

1. Jack up the trailer and secure on adequate capacity jack stands. Follow trailer manufacturer’s recommendations for lifting and supporting the unit. Check that the wheel and drum rotate freely.
2. Remove the adjusting hole cover from the adjusting slot on the bottom of the brake backing plate.
3. With a screwdriver or standard adjusting tool, rotate the starwheel of the adjuster assembly to expand the brake shoes. Adjust the brake shoes out until the pressure of the linings against the drum makes the wheel very difficult to turn.
4. Rotate the starwheel in the opposite direction until the wheel turns freely with a slight lining drag.
5. Replace the adjusting hole cover and lower the wheel to the ground.

Leaf Spring Suspension Systems

Suspension Types

Reliable offers two types of leaf spring suspension systems: the double eye leaf spring suspension and the slipper leaf spring suspension. Both Reliable leaf spring suspension systems are available in single and multiple axle configurations. Both types of suspensions can be mounted either in the overslung position (leaf spring mounted on the top of the axle beam) or in the underslung position (leaf spring mounted on the bottom of the axle beam).

Double Eye Spring Suspensions

Single Axle Double Eye Suspension

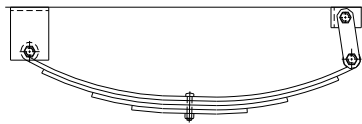

Tandem Axle Double Eye Suspension

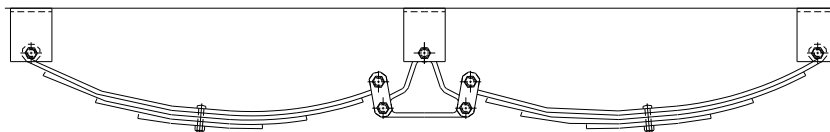

Double eye leaf springs have eyes formed in each end of the spring and are attached to the trailer as follows:

1. The front spring eye is attached directly to the front hanger with a bolt and nut.
2. The rear spring eye is attached to a pair of shackle links which are attached to either a rear hanger (in the case of a single axle installation), or an equalizer (in the case of a multiple axle installation).

The articulation of this suspension occurs when the spring becomes loaded and consequently lengthens. The double pivot action of the shackle links accommodates this articulation and allows the system to move freely.

In multiple axle installations the action is the same but with the additional movement of the equalizer assembly which serves to transfer instantaneous loads from one axle to another in an effort to “equalize” the load between the axles.

Slipper Spring Suspensions

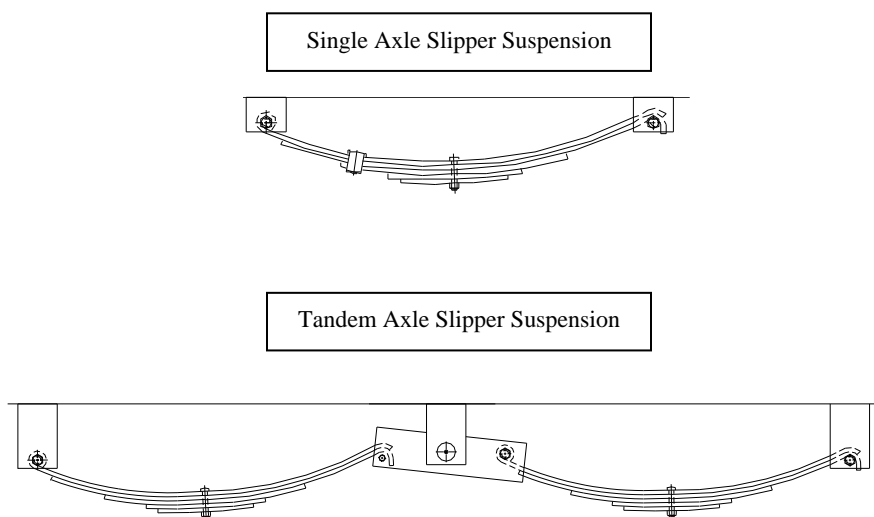

Slipper springs have an eye formed in one end only with the other end formed into a reverse curve. The attachment of these springs is as follows:

1. The front eye is attached directly into the front hanger with a bolt and nut.
2. The rear end of the spring is captured in the rear hanger or equalizer with a “keeper bolt” that prevents the spring from coming out when the trailer is jacked up for service.

The articulation of this suspension occurs when the rear end of each slipper spring slides against the wear surfaces provided in the rear hangers or equalizers. This suspension is also available in single and multiple axle configurations.

Leaf Spring Suspension – Inspection and Maintenance

The mounting components of your leaf spring suspension system need to be inspected at least every 6,000 miles, or as use requires, for signs of excessive or abnormal wear, elongation of bolt holes, and loosening of any fasteners. Whenever a fastener is loose or must be replaced, the following guidelines should be followed for torque specifications.

Suspension Fastener Torque Values		
Item	Torque Min. (ft./lbs.)	Torque Max. (ft./lbs.)
½" U-Bolt	45	60
Shackle Bolt Spring Eye Bolt Equalizer Bolt	Snug fit only required. Parts must rotate freely. Lock nuts or cotter pins are provided to retain nut-bolt assemblies.	

Worn spring eye bushings and sagging or broken springs must be replaced using the following method:

1. Lift and support the trailer frame following the manufacturer's recommendations for supporting the trailer. *Do not lift or place supports on any part of the suspension system.*
2. After properly supporting the trailer frame, place a block under the end of the axle beam to be repaired. This block will serve as support for the weight of the axle during the changing of the component parts.
3. Disassemble the u-bolts, nuts, and tie plates from the axle beam.
4. Remove the eyebolts from the spring. The spring may then be removed for further work.
5. If in need of replacement, drive the existing spring eye bushings out of the spring using a punch.
6. Drive the replacement bushing into the spring using a piloted punch or close fitting bolt inserted through the bushing.
7. Reinstall the repaired or replaced components.

NOTE: For multiple axle suspension systems each axle must be supported as outlined in Step #2 prior to any disassembly of the suspension system.

All of the pivot points of the leaf spring suspension system have been fitted with anti friction bearing materials that do not require routine lubrication. However, when otherwise servicing the unit, these pivot points may be lubricated if you so desire.

Rubber Torsion Suspension Systems

The Reliable Rubber Torsion Suspension System is a self-contained suspension system that is housed entirely inside the axle beam. Unlike the spring suspension system, the axle beam attaches directly to the trailer frame without the need for various mounting components. The action provided by the Rubber Torsion Suspension System is unique from the leaf spring suspension providing several operating advantages including independent suspension and a virtually maintenance-free suspension system.

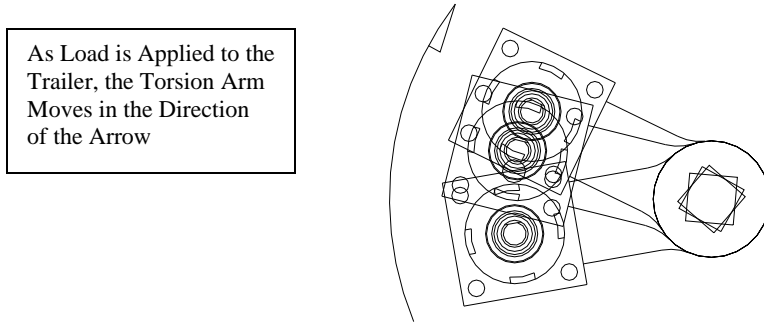

How the Rubber Torsion Suspension System Works

The Reliable Rubber Torsion Axle provides a much improved trailer ride relative to conventional spring axles through a unique arrangement of the steel torsion bar surrounded by four natural rubber cords encased in the main structural member of the axle beam. The wheel/hub spindle is attached to a lever, called the torsion arm assembly. This assembly includes the torsion arm, the torsion bar and spindle. As load is applied to the trailer, the torsion arm assembly pivots around the torsion bar, causing a rolling or compressive resistance in the rubber cords inside of the axle beam. Both sides of the axle are completely independent from one another.

Direction of Travel

All Reliable Rubber Torsion axle beams and stub axles must be mounted with the torsion arm and spindle trailing to the rear of the axle beam.

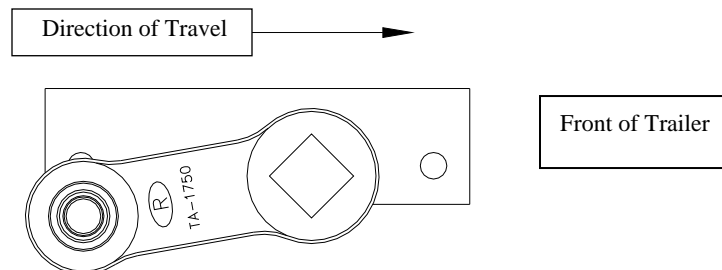

Rubber Torsion Suspension – Inspection and Maintenance

Except for periodic inspection of the fasteners used to attach the Rubber Torsion axle to the trailer frame and a visual inspection of the welds, no other suspension maintenance is required. However, all maintenance regarding brakes, hubs, drums, rotors, bearing, wheels, and tires, as outlined on page 28 of this manual, should be adhered to.

Wheels and Tires

Wheel Selection

Wheels are a critical component of your running gear system. When specifying or replacing your trailer wheels it is important that the wheels, tires, and axle are properly matched. The following characteristics are extremely important and should be thoroughly checked when replacement wheels are considered.

1. **Bolt Circle.** Many bolt circle dimensions are available and some vary by so little that it might be possible to attach an improper wheel that does not match the hub. Be sure to match your wheel to the hub.
2. **Capacity.** Make sure that the wheels have enough load carrying capacity and pressure rating to match the maximum load of the tire and trailer.
3. **Offset.** This refers to the relationship of the centerline of the tire to the hub face of the axle. Care should be taken to match any replacement wheel with the same offset wheel as originally equipped. Failure to match offset can result in reducing the load carrying capacity of your axle.
4. **Rim Contour.** Use only the approved rim contours as shown in the Tire and Rim Association Yearbook or the tire manufacturer's catalog. The use of other rim contours is dangerous. Failure to use the proper rim contour can result in explosive separation of the tire and wheel and could cause a serious accident.

Torque Requirements

It is extremely important to apply and maintain proper wheel mounting torque on your trailer axle. Torque wrenches are the best method to ensure the proper amount of torque is being applied to a fastener.

It is important that the specified torque levels are maintained on the wheel nuts or bolts on your axle to prevent loose wheels, broken wheel studs, and possible wheel separation from the axle.

Wheel nuts and bolts are offered in different cone angles (usually 60° or 90°). It is important to match the angle of the fastener to the wheel on the axle.

The proper procedure for the attachment of your wheels is listed below.

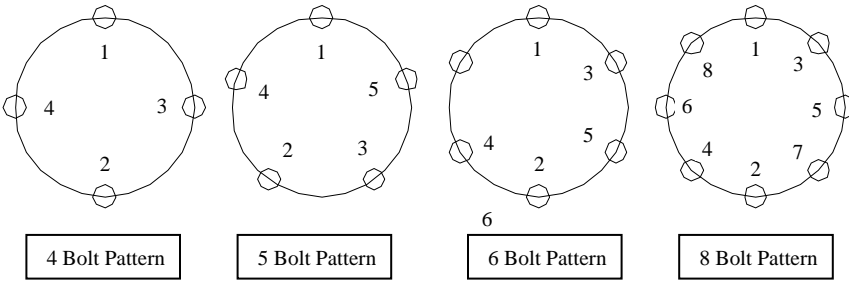

1. Start all bolts or nuts by hand to prevent cross threading.
2. The tightening of the fasteners should be done in stages. Following the recommended sequence above, tighten fasteners per the wheel torque chart below.
3. Wheel fasteners should be torqued before the first initial road usage and after each wheel removal. Check and retorque the wheel fasteners after the first 10 miles, 25 miles, 50 miles and again at 250 miles. Check periodically thereafter to ensure that the proper torque values are maintained.

Wheel Torque Values			
Wheel Size	1 st Stage	2 nd Stage	3 rd Stage
12"	20-25 ft./lbs.	35-40 ft./lbs.	* 60-75 ft./lbs.
13"	20-25 ft./lbs.	35-40 ft./lbs.	* 60-75 ft./lbs.
14"	20-25 ft./lbs.	50-60 ft./lbs.	* 90-120 ft./lbs.
15"	20-25 ft./lbs.	50-60 ft./lbs.	* 90-120 ft./lbs.
16"	20-25 ft./lbs.	50-60 ft./lbs.	* 90-120 ft./lbs.

**Values shown may have to be adjusted depending on the type of wheel used. Please consult the wheel manufacturer for further information.*

Tires







Before mounting tires onto wheels, make certain that the rim size and contour is approved for the tire as shown in the Tire and Rim Association Yearbook or the tire manufacturer's catalog. Also make sure that the tire can carry the maximum rated capacity of the trailer.

Like the tires on a car, the most important factor in the life of the tires on your trailer is their inflation pressure. Check with your particular tire manufacturer for the amount of pressure for the specific capacity of your trailer. During use of your trailer, inflation pressure should be checked weekly and performed when the tires are cold (prior to operation of the trailer). In doing this, you will ensure that you are achieving the maximum life and tread wear for your tires.

Wheels and Tires – Inspection and Maintenance

Wheels should be visually checked periodically for dents or cracks. Whenever it is required to have a tire replaced on a rim, the wheel needs to be checked for balance and distortion.

Tire wear should also be checked often for abnormal or excessive wear. The following chart will aid you in troubleshooting if abnormal or excessive tire wear should occur. It is important to monitor tire wear, as once a wear pattern becomes firmly established in a tire it is difficult to stop, even if the underlying cause is corrected.

Tire Wear Diagnostic Chart			
Wear Pattern		Cause	Action
	Center Wear	Overinflated tire	Adjust tire pressure to specific load rating per tire catalog.
	Edge Wear	Underinflated tire	Adjust tire pressure to specific load rating per tire catalog.
	Side Wear	Loss of camber or overloading	Make sure load does not exceed axle rating. Realign axle at alignment shop.
	Toe Wear	Incorrect toe-in	Align at alignment shop.
	Cupping	Out-of-balance	Check bearing adjustment and balance tires.
	Flat Spots	Wheel lockup and tire skidding	Avoid sudden stops when possible and adjust brakes.

Operation

Storage Preparation

It is important that your trailer running gear be prepared properly for extended or winter storage. The following precautions should be taken to avoid any problems when your trailer is removed from storage.

1. Following the trailer manufacturer's recommendations, block up and support the trailer frame. This will prevent the weight of the trailer frame from being unnecessarily kept on the tires for the duration of storage. Never jack up or support the trailer on any part of the suspension system.
2. Lubricate and inspect mechanical moving parts such as the trailer hitch and suspension parts, which are exposed to the weather.
3. Boat trailer axles that are subject to repeated immersion should have the brake drums removed, cleaned, and relubricated prior to storage.

Service After Prolonged Storage

Before removing your trailer from the supports it is important to follow the guidelines below for proper maintenance:

1. Remove and/or relubricate each hub and brake drum. When reinstalling, make sure that the hub or drum is placed back on the spindle from which it was removed.
2. Inspect the suspension components for wear. Replace or recondition any worn parts.
3. Check torque values of all suspension fasteners per the torque value chart in this manual.
4. Check brake linings and shoes on all brakes. The rotor or brake drum surfaces should also be inspected for wear. Any corrosion on the braking or magnet surfaces should be removed using a fine emery cloth. Extra precaution should be taken to ensure that the bearings in the drum or rotor are not contaminated.
5. Lubricate all brake moving parts with a high temperature brake lubricant. Be careful not to get any lubricant on the brake linings.
6. Grease seals should be inspected for wear and nicks in the sealing lip. If necessary replace using the recommended seal for your application.
7. Reinstall the hubs and adjust the bearings per the instructions in this manual.
8. Mount and retorque the wheels per the torque values in this manual.

Trip Preparation Checklist

It is extremely critical to follow the steps on this checklist prior to starting a trip with your trailer. By doing so, you are assured that you are taking all the necessary precautions to extend the life of your suspension system. Be sure to allow yourself sufficient time to perform the maintenance required.

1. Check your maintenance schedule to ensure that all routine maintenance matters are current. Perform any neglected maintenance.
2. Check the trailer hitch for signs of wear. Lubricate the hitch if necessary.
3. Make sure that the breakaway battery is charged and inspect safety chains.
4. Inspect the tow vehicle's towing hookup.
5. Load the trailer and adjust the tongue weight so that 8% - 10% of the load is on the tongue.
6. Ensure that you are not overloaded and are staying within the capacity rating of the trailer.
7. Inspect tires for wear and adjust tire pressure according to the tire manufacture's recommendations.
8. Check wheel nut or bolt torque values. Adjust per the specifications in this manual.
9. Make sure that the brakes are adjusted and synchronized properly.
10. Check all suspension fasteners and retorque if necessary following the procedures outlined in this manual.
11. Check all light operation. Replace any faulty bulbs.
12. Check and adjust your tow vehicle's tow height to make sure that the trailer is being towed level.

Maintenance Schedule

Below is a maintenance schedule for routine maintenance of your trailer.

Item	Function Required	3 Months or 1000 Miles	6 Months or 3000 Miles	12 Months or 6000 Miles	Refer to Page
Brakes	Test operation	Every use			
Brake Adjustment	Adjust to proper setting	•			14 & 20
Brake Magnets	Inspect for wear & current draw		•		19
Brake Linings/Pads	Inspect for wear & contamination			•	13 & 19
Brake Calipers	Inspect for wear & functionality			•	8
Brake Cylinders	Check for leaks & operation			•	13
Hydraulic System	Check for operation			•	13
Brake Lines	Inspect for cracks, kinks & leaks			•	13
Hub/Drum/Rotor	Inspect for abnormal wear			•	2
Bearings – Grease Without Lube System	Inspect for wear Clean & Repack			•	4
Bearings – Grease With Lube System	Replenish grease in the system		•		5
Bearings – Oil Oil Bath Lube System	Replenish oil if needed	•			6
Seals	Inspect for leakage Replace if worn			•	3
Leaf Springs	Inspect for wear and sagging			•	22
Suspension Parts	Inspect for bending & wear		•		22
Hangers & Brackets	Inspect all welds			•	22
Attaching Fasteners	Check torque values & tightness			•	22
Wheel Nuts & Bolts	Check torque values	•			24

Warranty Policy

Reliable Production Machining & Welding warrants their products to be free from defects in workmanship and material under normal service and use. Warranty of component parts purchased from outside manufacturers for resale by Reliable shall be limited to the warranty of the respective manufacturer of such parts. The exclusive remedy offered under this warranty is repair or replacement of a covered defect and Reliable shall determine whether repair or replacement is appropriate. Reliable's obligation under this warranty is limited to the repair or replacement of the defective parts and is not liable for any incidental or consequential damages to property or persons, including any towing fees, hotel expenses, telephone calls and meals.

In all cases, written authorization for the return of defective parts must be obtained from Reliable. Upon receipt, the defective parts are subject to Reliable's inspection to determine their condition before the disposition of credit will be allowed.

This warranty is exclusive and in lieu of all other warranties except that of title, whether written, oral or implied. Any warranty in act or in law including ny warranty of merchantability or fitness for a particular purpose, are hereby excluded from this contract.

Reliable's responsibility ceases with delivery to the carrier, at which time title passes to the purchaser and all claims for loss, damage and delay must be made to the carrier by the purchaser. Reliable is not responsible for non-delivery or delay in delivery due to delays, damages or losses resulting from strikes, riots, fires, floods, inability to secure materials or other accidents or occurrences beyond Reliable's control.

Some states do not allow the exclusion or limitations of incidental or consequential damages, therefore the above limitations may not apply to all customers.

1) Warranty Coverage

All workmanship provided by Reliable, along with the parts and components we manufacture are covered by this warranty. The use of these products for other than their intended use for free rolling applications, such as driven wheels, power steering, tandem and triple axles, hillside operations and rough terrain use, or alterations made to Reliable's products without written approval, void all terms of this warranty.

2) Warranty Duration.

The warranty periods listed below are effective from the date of shipment or proof of original date parts were put into service, and are extended to the original purchaser of the product only.

- **Rubber Torsion Axles**
A warranty period of five (5) years is extended to all Reliable rubber torsion axles and covers the axle beam only.
- **Leaf Spring Axles**
A warranty period of one (1) year is extended to all Reliable leaf spring axles and covers the axle beam only.
- **Assembled Units with Lube Systems (Sure Lube, Bearing Lube, Oil Bath).**
A warranty period of three (3) years is extended to all assembled units with Lube Systems. This warranty excludes brakes, which are subject to the brake manufacturer's warranty. Any disassembly of the unit or replacement of parts from within the unit voids this warranty.
- **Assembled Units without Lube Systems.**
A warranty period of one (1) year is extended to all assembled units without Lube Systems. This warranty excludes brakes, which are subject to the brake manufacturer's warranty. Any disassembly of the unit or replacement of parts from within the unit voids this warranty.
- **Hubs, Drums & Spindles**
A warranty period of one (1) year is extended to all hubs, drums and spindles manufactured by Reliable.
- **Reliable Disc Brake System**
A warranty period of two (2) years is extended to the Reliable Disc Brake System. This includes the rotor and caliper assembly (excluding the disc brake pads).
- **Reliable Surge Brake Actuator**
A warranty period of two (2) years is extended on all surge brake actuators manufactured by Reliable.

3) Non-Coverage Items

This warranty does not extend to or cover defects caused by:

- Improper wiring of the brake to the trailer or the towing vehicle.
- The attachment of the axle assembly to the trailer.
- Additional costs incurred for replacement, removal or reinstallation. Including any towing fees, hotel expenses, telephone calls and meals.
- Parts not supplied or manufactured by Reliable.
- Return freight charges.
- Any damage caused or related to alterations to Reliable's products.
- Normal usage or wear.
- Alignment.
- Improper installation or assembly performed by another party other than Reliable.
- Unreasonable operation. Including failure to provide reasonable and necessary maintenance.
- Improper wheel nut torque.
- The welding of supplemental mounting brackets or members to the existing axle beam.
- Damage incurred while parts are in transit to the purchaser.
- Non-standard production parts.

4) Warranty Service

To obtain warranty service the following information must be supplied to Reliable by the purchaser.

- Contact information. Name, mailing address, telephone and fax number of the purchaser.
- Proof of date of purchase or original date parts were put into service.
- Model, year & serial number, if applicable, of product.
- Detailed description of defect.

All returned warranty claims must be given written authorization by Reliable. Returned merchandise must be returned freight prepaid by the customer.

ALL ORDERS RECEIVED BY RELIABLE TOOL & MACHINE ARE AN INDICATION THAT THE CUSTOMER HAS READ, FULLY UNDERSTANDS, AND ACCEPTS ALL OF THE TERMS AND CONDITIONS OF THIS WARRANTY POLICY.



Reliable Production Machining & Welding

P.O. Box 757
300 West Ohio St.
Kendallville, IN 46755

Reliable PMW – Kendallville, IN

Kendallville, IN 46755
Phone: 260-347-4000
Toll Free: 888-347-5566
Fax: 260-347-5552